



HERCULES
CARPARKING SYSTEMS

Hercules DS2300

The Hercules Double Stacker Series is the ultimate car parking solution to accommodate two cars in the one carpark space above ground. The sleek design and strong, galvanised construction guarantee safety, durability and the utmost protection of both the cars and drivers/passengers. The simplicity of operation, and it's economic and practical design make the Hercules DS Series the unchallenged leader in the field of safe car parking practices.

FEATURES OF THE DS2300

- 2300kg lift capacity
- Commercial grade design
- Middle post feature saves cost and space
- Dynamic mechanical locks as anti-falling device holds the platform in place
- Galvanised and corrugated platform
- Anti-slip corrugated deck, protects both the vehicles and drivers from possible slip/damage.
- High-heeled shoe friendly
- Single hydraulic lifting cylinders with chains as drive system
- The pole with piston is chromic to anti-corrode, ensures long lasting durability
- Individual hydraulic power pack and control panel
- Self-standing and self-support structure
- Symmetrical designed column
- Special design control arm for operator to control the lift without getting under the platform
- Synchronisation chain, assures the lifting platform is balanced
- Electric key switch for security and safety
- A new "Lock Down" button for the platform, sits on the locking tab to protect the cylinder
- Automatic shutdown if operator releases key switch
- Manual lock release available in the case of an electricity failure
- Platform can be stopped at different heights to accommodate for various vehicles & ceiling heights
- Hydraulic overloading protection



MODEL	DS2300
Lifting Capacity	2300kg
Equipment Weight	1000kg
Lifting Height	2100mm
Useable Platform Width	2100mm
Electrical Required	220-420V, 1 or 3Phase, 50/60Hz
Control Power	24V
Lock Device	Dynamic
Lock Release	Electric auto release
Operation	Key switch
Power Pack	2.2 kw hydraulic power pump
Lifting/Lowering Time	50/45 seconds
Finishing	Powder coating

Hercules Carparking Systems 2004 Pty Ltd

Unit 1, 87 Reserve Road
ARTARMON NSW 2064
Toll Free: 1800 649 603
Ph: (02) 9966 5600 Fax: (02) 9966 5622
info@hercules.com.au
www.hercules.com.au



HERCULES
CARPARKING SYSTEMS

SPECIFICATIONS OF THE DS2300

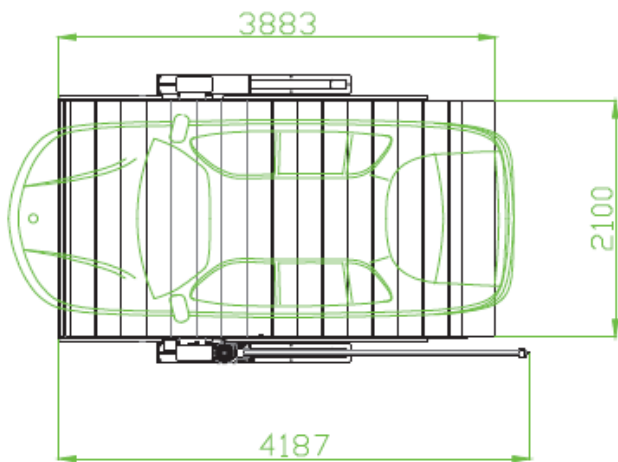
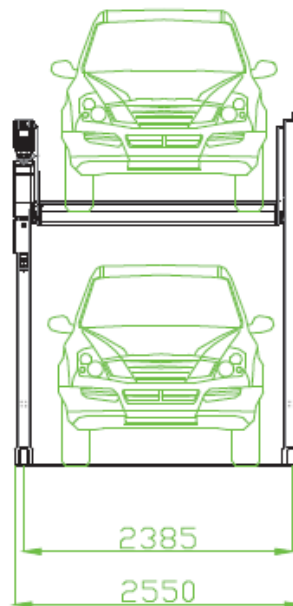
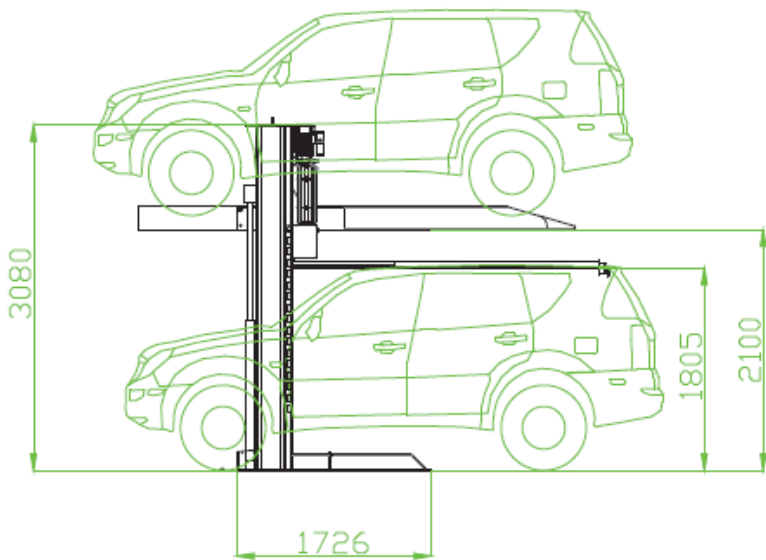

	Type	
Parking	Parking Vehicles	2
	Single vehicles weight(kg)	<2300kg
Size of car	Length	5000mm
	Width	1850mm
	Height	1550mm-2050mm
	Pump motor	2.2kw
	Lifting speed(seconds)	<55
	Electricity	380V 50Hz 3 phases or 220V 50Hz 1 phases

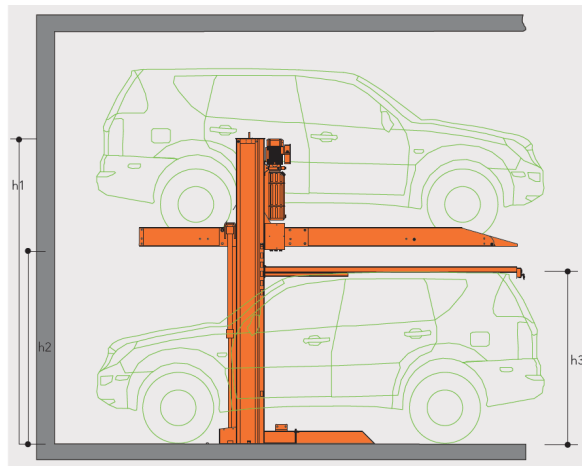

h1(mm)	3080
h2(mm)	2100
h3(mm)	1805

Hercules Carparking Systems 2004 Pty Ltd

Unit 1, 87 Reserve Road
ARTARMON NSW 2064

Toll Free: 1800 649 603

Ph: (02) 9966 5600 Fax: (02) 9966 5622

info@hercules.com.au

www.hercules.com.au